

EHX*E Series Enclosure

SPECIALTY, OUTDOOR, EXPLOSIONPROOF

Product Features

- Aluminum Construction
- Adjustable Mounting Cradle
- Available in 4-inch (10.16 cm), 6-inch (15.24 cm) and 8-inch (20.32 cm) Diameters
- For use in a Variety of Harsh and/or Hazardous Environments, including Marine Environments
- Meets NEMA Type 4X and IP66 Standards
- Use with Fixed Mount or Explosionproof Pan/Tilt



The **EHX*E Series** explosionproof camera enclosures are used in explosive and hazardous atmospheres throughout the world. They are designed to meet the rigorous requirements of explosionproof and dust-ignitionproof electrical equipment for installation and use in hazardous locations. These enclosures are also waterproof and dust tight.

Constructed of aluminum, enclosures in this series are available in 4-inch (10.16 cm), 6-inch (15.24 cm), and 8-inch (20.32 cm) diameters to accommodate most camera and lens combinations. A unique camera mounting sled and track assembly allows fast, easy positioning of the camera and lens and can be securely locked in place.

Field-installed accessories include optional heater, blower and sun shroud.

You can use the **EHX*E Series** in fixed mount applications or with Pelco's PT1260EX Series explosion-proof pan/tilt.

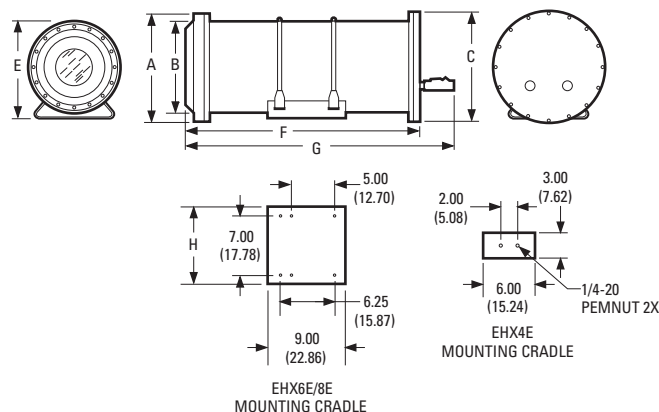

DIM	EHX4E	EHX6E-16	EHX6E	EHX8E
A	Ø7.00 (17.78)	Ø8.00 (20.32)	Ø8.00 (20.32)	Ø10.13 (25.72)
B	Ø4.50 (11.43)	Ø6.63 (16.83)	Ø6.63 (16.83)	Ø8.63 (21.92)
C	Ø7.00 (17.78)	Ø8.75 (22.23)	Ø8.75 (22.23)	Ø13.00 (33.02)
D	Ø3.19 (8.10)	Ø3.00 (7.62)	Ø3.00 (7.62)	Ø4.25 (10.80)
E	6.75 (17.15)	7.85 (19.94)	7.85 (19.94)	9.65 (24.51)
F	14.25 (36.20)	18.70 (47.50)	26.70 (67.82)	26.67 (67.74)
G	18.25 (46.36)	22.70 (57.66)	30.70 (77.98)	30.67 (77.90)
H	N/A	8.57 (21.77)	8.57 (21.77)	9.12 (23.16)

NOTE: VALUES IN PARENTHESES ARE CENTIMETERS; ALL OTHERS ARE INCHES.



C417 / REVISED 1-06

IP66



International Standards
Organization Registered Firm;
ISO 9001 Quality System



TECHNICAL SPECIFICATIONS

MODELS

EHX4E	Explosionproof enclosure, 4" diameter x 12" L (10.16 cm x 30.48 cm)
EHX6E	Explosionproof enclosure, 6" diameter x 24" L (15.24 cm x 60.96 cm)
EHX6E-16	Same as EHX6 except 16" L (40.64 cm)
EHX8E	Explosionproof enclosure, 8" diameter x 24" L (20.32 cm x 60.96 cm)

MECHANICAL

Cable Entry	2 explosionproof sealable fittings (supplied); 0.50-inch (1.27 cm) maximum inside diameter; pipe plug supplied for possible unused gland in rear plate	
Front Window	Fully tempered plate glass	
EHX4E	4.25" (10.80 cm) diameter, 0.475" (1.21 cm) thick	
EHX6E/EHX6E-16	4.50" (11.43 cm) diameter, 0.50" (1.27 cm) thick	
EHX8E	5.75" (14.92 cm) diameter, 0.50" (1.27 cm) thick	
Camera Mounting	Adjustable sled	
Maximum Camera and Lens Size*	<i>(Without Blower or Heater)</i>	
EHX4E	2.75" H x 3.375" W x 12.00" L (6.99 x 8.57 x 30.48 cm)	12.0" L x 3.0" diameter (30.48 x 7.62 cm)
EHX6E	3.75" H x 4.375" W x 24.00" L (9.53 x 11.11 x 60.96 cm)	24.0" L x 5.0" diameter (60.96 x 12.70 cm)
EHX6E-16	3.75" H x 4.375" W x 16.00" L (9.53 x 11.11 x 40.64 cm)	16.0" L x 5.0" diameter (40.64 x 12.70 cm)
EHX8E	5.75" H x 5.125" W x 24.00" L (14.60 x 13.02 x 60.96 cm)	24.0" L x 7.3" diameter (60.96 x 18.54 cm)
	<i>(With Heater Only)</i>	
EHX4E (only)	2.75" H x 3.375" W x 10.375" L (6.99 x 8.57 x 26.35 cm)	10.38" L x 3.00" diameter (26.36 x 7.62 cm)
EHX4E	2.75" H x 3.375" W x 9.00" L (6.99 x 8.57 x 22.86 cm)	9.0" L x 3.0" diameter (22.86 x 7.62 cm)
EHX6E	3.75" H x 4.375" W x 22.25" L (9.53 x 11.11 x 56.52 cm)	22.25" L x 5.00" diameter (56.52 x 12.70 cm)
EHX6E-16	3.75" H x 4.375" W x 14.25" L (9.53 x 11.11 x 36.20 cm)	14.25" L x 5.00" diameter (36.20 x 12.70 cm)
EHX8E	5.75" H x 5.125" W x 22.25" L (14.60 x 13.02 x 56.52 cm)	22.25" L x 7.30" diameter (56.52 x 18.54 cm)

*Assumes lens is fully extended.

GENERAL

Construction	Aluminum, pipe 6061T6	
Dimensions	See dimension drawing on front page	
Weight	Unit	Shipping
EHX4E	15 lb (6.79 kg)	19 lb (8.60 kg)
EHX6E	31 lb (14.04 kg)	36 lb (16.30 kg)
EHX6E-16	27 lb (12.23 kg)	32 lb (14.49 kg)
EHX8E	45 lb (20.41 kg)	53 lb (24.04 kg)

CERTIFICATIONS/RATINGS

- CE
- UL/cUL
- Classified by Underwriters Laboratories Inc. as to explosion and fire hazard only
- Type 4X enclosure for use in hazardous locations
- Class I, Groups C and D – Class II, Groups E, F, and G
- Class I, Zone 1, AEx d IIB, Ex d IIB
- ⓓ 03 ATEX 0318166U
- 0539 ⓧ II 2 G EEx d IIB
- ⓧ II 2 D, IP 66
- Suitable for marine outside (saltwater) use, for vessels over 65 feet in length

OPTIONAL ACCESSORIES

Blower Kit	BKX4000	Continuous duty blower kit for EHX4E only, 10 cfm, 120 VAC, 3.8 W at 60 Hz
	BKX4024	Same as BKX4000 except 19.4 cfm, 24 VDC (AC rectified), 1.92 W
	BKX6000	Continuous duty blower kit for EHX6E and EHX8E, 10 cfm, 120 VAC, 3.8 W at 60 Hz
	BKX6000/220	Same as BKX6000 except 8 cfm, 230 VAC, 9.6 W at 50 Hz
	BKX6024	Same as BKX6000 except 19.4 cfm, 24 VDC (AC rectified), 1.92 W
Heater Kit	HKX4-1*	Heater kit for EHX4E only, 120 VAC, 40 W
	HKX4-2*	Same as HKX4-1 except 24 VAC
	HKX4-3*	Same as HKX4-1 except 230 VAC, 80 W
	HKX6-1*	Heater kit for EHX6E only, 120 VAC, 80 W
	HKX6-2*	Same as HKX6-1 except 24 VAC
	HKX6-3*	Same as HKX6-1 except 230 VAC
	HKX8/10-1*	Heater kit for EHX8E only, 120 VAC, 107 W
	HKX8/10-2*	Same as HKX8-1 except 24 VAC
	HKX8/10-3*	Same as HKX8-1 except 230 VAC
Sun Shroud	SSEHX4E	Sun shroud for EHX4E only
	SSEHX6E	Sun shroud for EHX6E only
	SSEHX6E-16	Sun shroud for EHX6E-16 only
	SSEHX8E	Sun shroud for EHX8E only
Other	EHX*EORKIT	O-ring kit for EHX*E Series. Consult factory for applicable model numbers

*Heaters activate on at 40°F (4°C) and off at 60°F (15°C)

RECOMMENDED MOUNTS

EHX4E	EM1109, EM2000, EM2200	Medium duty mount for horizontal/vertical pipe or pole; maximum load 40 lb (18.1 kg)
	EM22	Medium duty wall mount; maximum load 40 lb (18.1 kg)
	MM22	Medium duty ceiling/pedestal mount; maximum load 40 lb (18.1 kg)
EHX6E/EHX8E	PM2000, PM2010**	Pedestal/ceiling mount; maximum load 125 lb (56.62 kg)
	WM2000**	Wall mount; maximum load 75 lb (34 kg); increased to 150 lb (68 kg) when used with ST1 strut
	WM3026	Heavy duty wall mount with adjustable head; maximum load 300 lb (136 kg)
Adapters	AH2000	Adjustable head
	ST1	Support strut

**Use with AH2000 adjustable head.

RECOMMENDED PAN/TILT

PT1260EX Series	Heavy duty explosionproof pan/tilt; maximum load 100 lb (45.4 kg)
-----------------	---



Pelco, Inc. Worldwide Headquarters:
3500 Pelco Way, Clovis, California 93612-5699 USA
USA & Canada Tel: (800) 289-9100 • FAX: (800) 289-9150
International Tel: +1 (559) 292-1981 • FAX: +1 (559) 348-1120
www.pelco.com

Pelco and the Pelco logo are registered trademarks of Pelco, Inc. Product specifications and availability subject to change without notice. ©Copyright 2006, Pelco, Inc. All rights reserved.